

Particle Physics

Dr M.A. Thomson

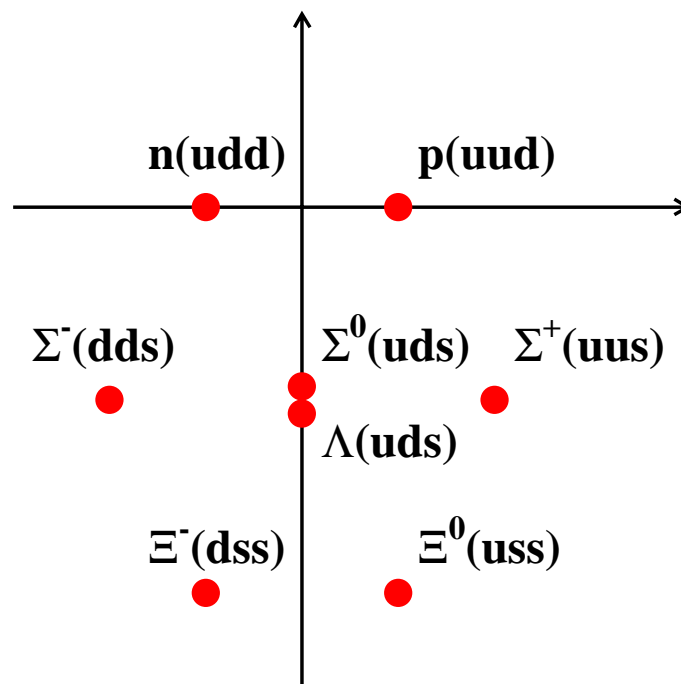
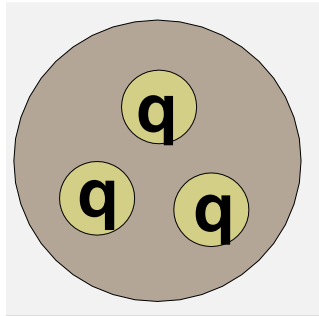

Part II, Lent Term 2004 HANDOUT IV

The Quark Model of Hadrons

EVIDENCE FOR QUARKS

- ★ The magnetic moments of proton and neutron are not $\frac{e\hbar}{2m_p}$ and 0 \Rightarrow not point-like
- ★ electron-proton scattering at high q^2 deviates from Rutherford scattering \Rightarrow proton has sub-structure
- ★ jets are observed in e^+e^- and $p\bar{p}$ collisions
- ★ symmetries (patterns) in masses/properties of hadron states, “quarky” periodic table \Rightarrow sub-structure
- ★ R_μ
- ★ Observation of $c\bar{c}$ and $b\bar{b}$ bound states.
- ★ and much, much more.....

Here we will first consider the wave-functions for hadrons formed from the light quarks (up, down, strange) and deduce their static properties (mass and magnetic moments). Then we will go on to discuss the heavy quarks, charm, bottom (sometimes called beauty), and top.

Hadron Wave-functions in the Quark Model

★ Due to properties of QCD quarks are always confined to hadrons (i.e. colourless states).

MESONS
SPIN-0,1,...

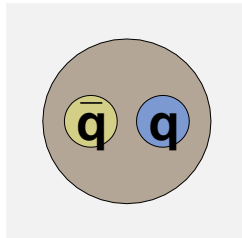

BARYONS
SPIN- $\frac{1}{2}, \frac{3}{2}$,

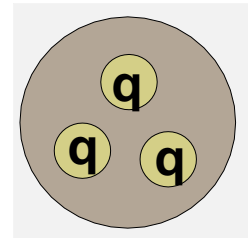

★ Last year several reports of observations of pentaquark bound states $qqqq\bar{q}$

HADRON WAVE-FUNCTIONS

Treat quarks as IDENTICAL fermions with states labelled with SPATIAL, SPIN, FLAVOUR, COLOUR

$$\psi = \psi_{\text{space}} \psi_{\text{flavour}} \psi_{\text{spin}} \psi_{\text{colour}}$$

★ All hadrons are COLOUR SINGLETs, i.e. net colour zero

$$\psi_{\text{colour}}^{q\bar{q}} = \frac{1}{\sqrt{3}} (r\bar{r} + g\bar{g} + b\bar{b})$$

$$\psi_{\text{colour}}^{qqq} = \frac{1}{\sqrt{6}} (rgb + gbr + brg - grb - rbg - bgr)$$

Consider ground state i.e. (L=0) mesons and baryons

- ★ Determine wave-functions
- ★ Determine parity
- ★ Calculate masses
- ★ Calculate magnetic moments

Parity

★ Parity operator, \hat{P} , \rightarrow SPATIAL INVERSION

$$\hat{P}\psi(\tilde{\mathbf{r}}, t) = \psi(-\tilde{\mathbf{r}}, t)$$

★ The Eigenvalue of \hat{P} is called PARITY

$$\hat{P}\psi = P\psi, \quad P = \pm 1$$

★ Particles are EIGENSTATES of PARITY and in this case P represents the INTRINSIC PARITY of a particle/anti-particle.

★ Parity is a useful concept. IF the Hamiltonian for an interaction commutes with \hat{P}

$$[\hat{P}, \hat{H}] = 0$$

then PARITY IS CONSERVED in the interaction:

★ PARITY CONSERVED in STRONG interaction

★ PARITY CONSERVED in EM interaction

★ but NOT in the WEAK interaction

★ Composite system of 2 particles with orbital angular momentum L :

$$P = P_1 P_2 (-1)^L$$

Quantum Field Theory:

fermions/anti-fermions : OPPOSITE parity

bosons/anti-bosons : SAME parity

Choose:

quarks/leptons : $P = +1$

anti-quarks/anti-leptons : $P = -1$

Gauge Bosons (γ, g, W, Z) are vector fields which transform

as $J^P = 1^-$

SPIN

QM Revision

Quantum Mechanical LADDER operators, $\hat{J}_{\pm} = \hat{J}_x \pm i\hat{J}_y$

$$\hat{J}_+|j, m\rangle = \sqrt{j(j+1)-m(m+1)}|j, m+1\rangle$$

$$\hat{J}_-|j, m\rangle = \sqrt{j(j+1)-m(m-1)}|j, m-1\rangle$$

For Example - can generate all $|j, m\rangle$ states from $|j, j\rangle$

$$|1, 1\rangle = |\frac{1}{2}, \frac{1}{2}\rangle|\frac{1}{2}, \frac{1}{2}\rangle = \uparrow\uparrow$$

Since \hat{J}_x etc. formed from derivatives use product rule,
 $d(uv) = udv+vdu$, when acting on product of states:

$$\hat{J}_-|1, 1\rangle = (\hat{J}_-|\frac{1}{2}, \frac{1}{2}\rangle)|\frac{1}{2}, \frac{1}{2}\rangle + |\frac{1}{2}, \frac{1}{2}\rangle(\hat{J}_-|\frac{1}{2}, \frac{1}{2}\rangle)$$

$$\sqrt{2}|1, 0\rangle = |\frac{1}{2}, -\frac{1}{2}\rangle|\frac{1}{2}, \frac{1}{2}\rangle + |\frac{1}{2}, \frac{1}{2}\rangle|\frac{1}{2}, -\frac{1}{2}\rangle$$

$$|1, 0\rangle = \frac{1}{\sqrt{2}}(\uparrow\downarrow + \downarrow\uparrow)$$

For the combination of two spin half particle:

$$|1, 1\rangle = \uparrow\uparrow$$

$$|1, 0\rangle = \frac{1}{\sqrt{2}}(\uparrow\downarrow + \downarrow\uparrow)$$

$$|1, -1\rangle = \downarrow\downarrow$$

All SYMMETRIC under interchange of 1 \leftrightarrow 2

Also an orthogonal combination which is

ANTI-SYMMETRIC under under interchange of 1 \leftrightarrow 2

$$|0, 0\rangle = \frac{1}{\sqrt{2}}(\uparrow\downarrow - \downarrow\uparrow)$$

Light Mesons

Mesons are bound $q\bar{q}$ states. Here we consider only mesons consisting of **LIGHT** quarks (u, d, s).

$$m_u \sim 0.3 \text{ GeV}, \quad m_d \sim 0.3 \text{ GeV}, \\ m_s \sim 0.5 \text{ GeV}$$

Ground state ($L = 0$)

For ground states, where orbital angular momentum is zero, the meson “spin” (total angular momentum) is determined by the $q\bar{q}$ spin state.

Two possible $q\bar{q}$ total spin states $S = (0, 1)$

★ $S = 0$: pseudo-scalar mesons

★ $S = 1$: vector mesons

Meson Parity : (q and \bar{q} have **OPPOSITE** parity):

$$P = P(q)P(\bar{q})(-1)^L \\ = (+1)(-1)(-1)^L = -1 \quad (\text{for } L = 0)$$

Flavour States:

$u\bar{d}, u\bar{s}, d\bar{u}, d\bar{s}, s\bar{u}, s\bar{d}$

$(u\bar{u}, d\bar{d}, s\bar{s})$ **MIXTURES**

Expect :

9 $J^P = 0^-$ MESONS : **PSEUDO-SCALAR NONET**

9 $J^P = 1^-$ MESONS : **VECTOR NONET**

uds MULTIPLETS

QUARKS

“Strangeness”

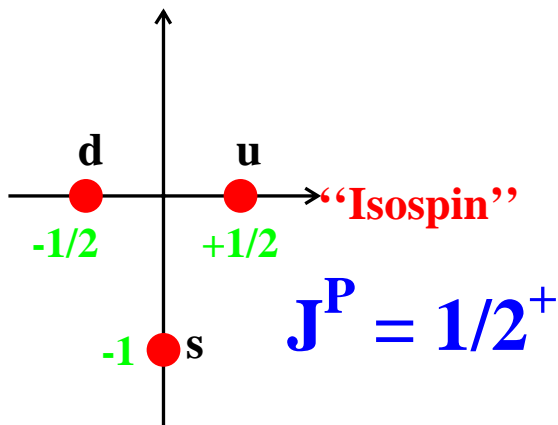

ANTIQUARKS

“Strangeness”

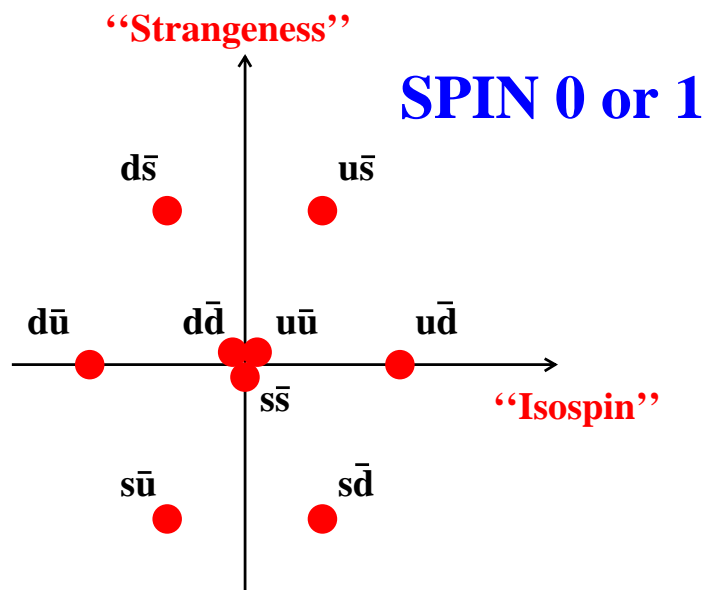
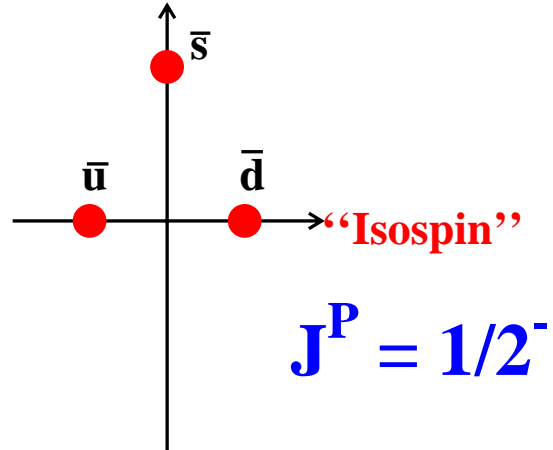

The ideas of **strangeness** and **isospin** are historical quantum numbers assigned to different states. Essentially they count quark flavours (this was all before the formulation of the quark model)

$$\text{Isospin} = \frac{1}{2} (n_u - n_d - n_{\bar{u}} + n_{\bar{d}})$$

$$\text{Strangeness} = n_{\bar{s}} - n_s$$

Light Mesons

ZERO ORBITAL ANGULAR MOMENTUM

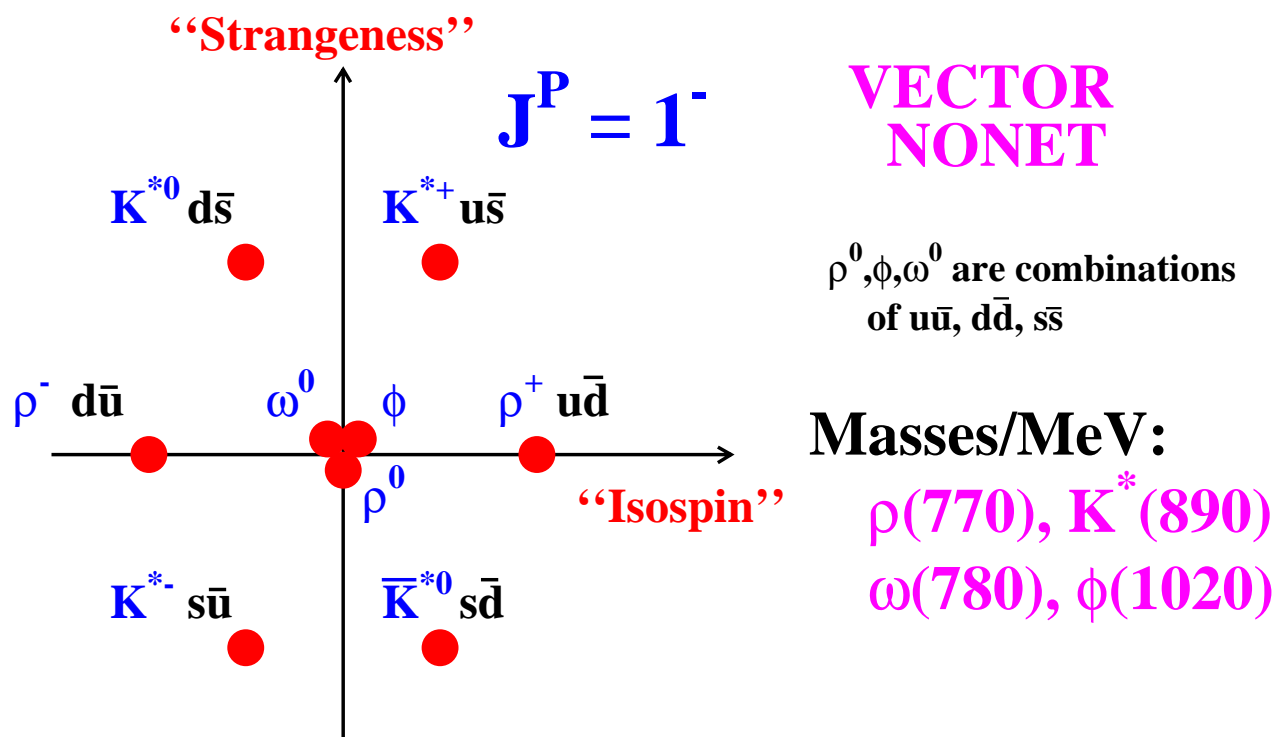
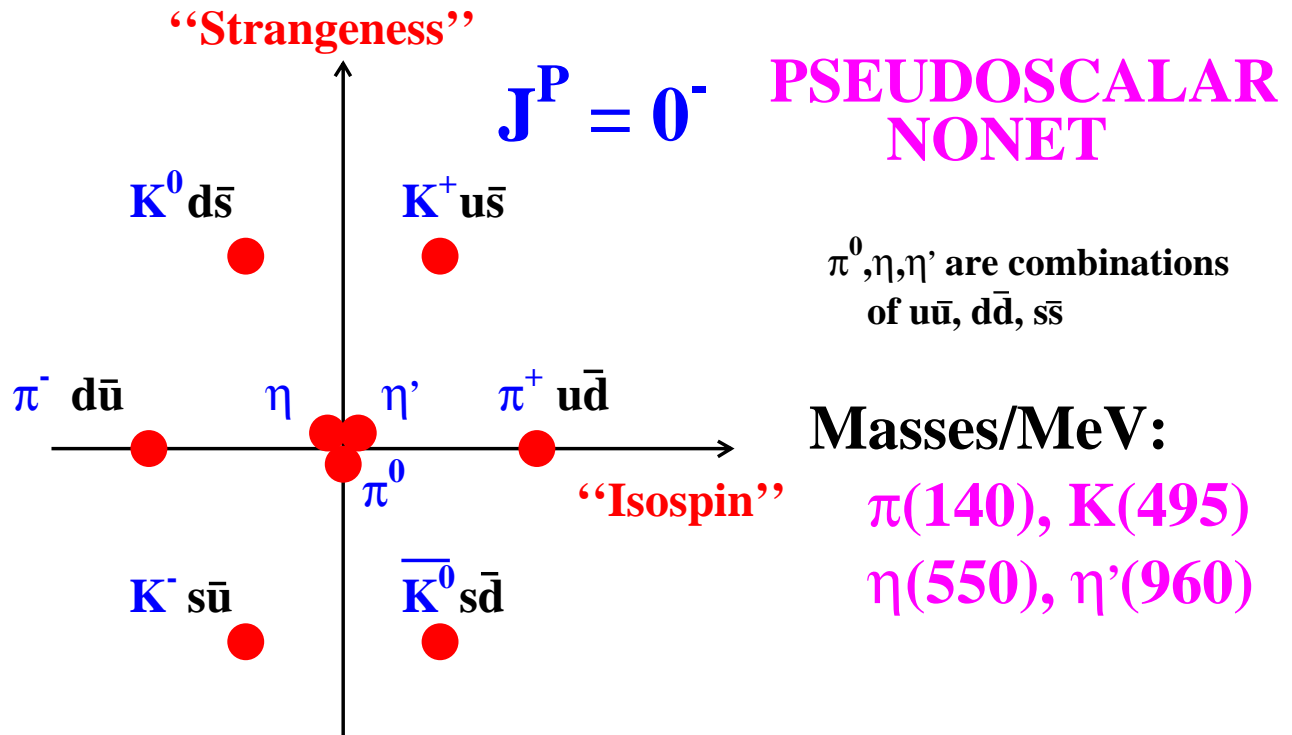

Meson Wave-functions

- ★ $u\bar{d}$, $u\bar{s}$, $d\bar{u}$, $d\bar{s}$, $s\bar{u}$, $s\bar{d}$ are straightforward
- ★ However, $(u\bar{u}, d\bar{d}, s\bar{s})$ states all have zero flavour quantum numbers - therefore can MIX

$$\left. \begin{aligned} \pi^0(140) &= \frac{1}{\sqrt{2}}(u\bar{u} - d\bar{d}) \\ \eta(550) &= \frac{1}{\sqrt{6}}(u\bar{u} + d\bar{d} - 2s\bar{s}) \\ \eta'(960) &= \frac{1}{\sqrt{3}}(u\bar{u} + d\bar{d} + s\bar{s}) \end{aligned} \right\} J^P = 0^-$$

$$\left. \begin{aligned} \rho^0(770) &= \frac{1}{\sqrt{2}}(u\bar{u} - d\bar{d}) \\ \omega^0(780) &= \frac{1}{\sqrt{2}}(u\bar{u} + d\bar{d}) \\ \phi(1020) &= s\bar{s} \end{aligned} \right\} J^P = 1^-$$

Mixing coefficients determined experimentally from masses, decays. e.g. leptonic decays of vector mesons

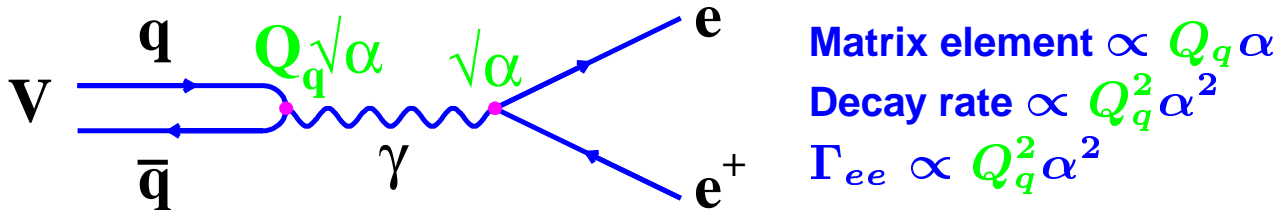

$$M_{fi}(\rho^0 \rightarrow e^+e^-) \sim e \frac{1}{q^2} \left[\frac{1}{\sqrt{2}} (Q_u e - Q_d e) \right]$$

$$\Gamma_{\rho^0 \rightarrow e^+e^-} \propto \left[\frac{1}{\sqrt{2}} \left(\frac{2}{3} - \left(-\frac{1}{3} \right) \right) \right]^2 = \frac{1}{2}$$

$$\Gamma_{\omega^0 \rightarrow e^+e^-} \propto \left[\frac{1}{\sqrt{2}} \left(\frac{2}{3} + \left(-\frac{1}{3} \right) \right) \right]^2 = \frac{1}{18}$$

$$\Gamma_{\phi \rightarrow e^+e^-} \propto \left[\frac{1}{3} \right]^2 = \frac{1}{9}$$

PREDICT: $\Gamma_{\rho^0} : \Gamma_{\omega^0} : \Gamma_{\phi} = 9 : 1 : 2$

EXPERIMENT: $8.8 \pm 2.6 : 1 : 1.7 \pm 0.4$

Meson Masses

Meson masses partly from constituent quark masses

★ $m(K) > m(\pi)$

hints at $m_s > m_u, m_d$

But that is not the whole story

★ $m(\rho^+) > m(\pi^+)$ (770 MeV c.f. 140 MeV)

but both are $u\bar{d}$

★ Only difference is in orientation of **Quark SPINS**

$\uparrow\uparrow$ vs. $\downarrow\uparrow$

SPIN-SPIN INTERACTION

QED: Hyperfine splitting in H_2 ($L=0$)

Energy shift due to electron spin in magnetic field of proton

$$\Delta E = \tilde{\mu} \cdot \tilde{B} = \frac{2}{3} \tilde{\mu}_e \cdot \tilde{\mu}_p |\psi(0)|^2$$

$$\text{using } \tilde{\mu} = \frac{e}{2m} \tilde{S}$$

$$\Delta E \propto \alpha_{em} \frac{\tilde{S}_e \cdot \tilde{S}_p}{m_1 m_2}$$

QCD: Colour Magnetic Interaction

Fundamental form of the interaction between a quark and a gluon is identical to that between an electron and a photon.

Consequently, also have a **COLOUR MAGNETIC INTERACTION**

$$\Delta E \propto \alpha_S \frac{\tilde{S}_1 \cdot \tilde{S}_2}{m_1 m_2}$$

MESON MASS FORMULA (L=0)

$$M_{q\bar{q}} = m_1 + m_2 + A \frac{\tilde{S}_1 \cdot \tilde{S}_2}{m_1 m_2}$$

where A is a constant

For a state of SPIN $\tilde{S} = \tilde{S}_1 + \tilde{S}_2$

$$\tilde{S}^2 = \tilde{S}_1^2 + \tilde{S}_2^2 + 2\tilde{S}_1 \cdot \tilde{S}_2$$

$$\tilde{S}_1 \cdot \tilde{S}_2 = \frac{1}{2}(\tilde{S}^2 - \tilde{S}_1^2 - \tilde{S}_2^2)$$

$$S_1^2 = S_2^2 = S_1(S_1 + 1) = \frac{1}{2}(1 + \frac{1}{2}) = \frac{3}{4}$$

giving $\tilde{S}_1 \cdot \tilde{S}_2 = \frac{1}{2}\tilde{S}^2 - \frac{3}{4}$

For

$$J^P = 0^- \text{ MESONS : } \tilde{S}^2 = 0$$

$$J^P = 1^- \text{ MESONS : } \tilde{S}^2 = S(S + 1) = 2$$

therefore

$$\tilde{S}_1 \cdot \tilde{S}_2 = \frac{1}{2}\tilde{S}^2 - \frac{3}{4} = -\frac{3}{4} \quad (0^- \text{ mesons})$$

$$\tilde{S}_1 \cdot \tilde{S}_2 = \frac{1}{2}\tilde{S}^2 - \frac{3}{4} = +\frac{1}{4} \quad (1^- \text{ mesons})$$

Giving the (L=0) Meson Mass formulae

$$M = m_1 + m_2 - \frac{3A}{4m_1 m_2} \quad (0^- \text{ mesons})$$

$$M = m_1 + m_2 + \frac{A}{4m_1 m_2} \quad (1^- \text{ mesons})$$

0^- mesons lighter than 1^- mesons

Can now try different values of $m_{u/d}$, m_s and A and try to reproduce the observed values.

Meson	Mass/MeV	
	Predicted	Experiment
π	140	138
K	484	496
ρ	780	770
ω	780	782
K^*	896	894
ϕ	1032	1019

Excellent agreement using:

$$m_u = m_d = 310 \text{ MeV},$$

$$m_s = 483 \text{ MeV},$$

$$A = 0.06 \text{ GeV}^3.$$

(see Question 4 on the problem sheet)

Bring on the Baryons.....

BARYON WAVE-FUNCTIONS

Baryons made from 3 indistinguishable quarks (flavour treated as another quantum number in the wave-function)

$$\psi_{\text{baryon}} = \psi_{\text{space}} \psi_{\text{flavour}} \psi_{\text{spin}} \psi_{\text{colour}}$$

ψ_{baryon} must be **ANTI-SYMMETRIC** under interchange of **any 2 quarks**.

Ground State (L=0)

Here we will only consider the baryon ground states. The ground states have zero **ORBITAL ANGULAR** momentum,

$$\Rightarrow \psi_{\text{space}} \text{ is symmetric}$$

★ All hadrons are **COLOUR SINGLET**S

$$\psi_{\text{colour}} = \frac{1}{\sqrt{6}} (rgb + gbr + brg - grb - rbg - bgr)$$

i.e. ψ_{colour} is anti-symmetric

$$\begin{array}{ll} \text{Therefore} & \psi_{\text{space}} \psi_{\text{colour}} \text{ is anti-symmetric} \\ \Rightarrow & \psi_{\text{spin}} \psi_{\text{flavour}} \text{ must be SYMMETRIC} \end{array}$$

★ Start with the combination of three spin-half particles.

Trivial to write down the spin wave-function for the $|\frac{3}{2}, \frac{3}{2}\rangle$ state :

$$|\frac{3}{2}, \frac{3}{2}\rangle = \uparrow\uparrow\uparrow$$

Generate the other states using \hat{J}_- .

$$\hat{J}_- |\frac{3}{2}, \frac{3}{2}\rangle = (\hat{J}_- \uparrow) \uparrow\uparrow + \uparrow (\hat{J}_- \uparrow) \uparrow + \uparrow\uparrow (\hat{J}_- \uparrow)$$

$$\sqrt{\frac{3}{2} \frac{5}{2} - \frac{3}{2} \frac{1}{2}} |\frac{3}{2}, \frac{1}{2}\rangle = \downarrow\uparrow\uparrow + \uparrow\downarrow\uparrow + \uparrow\uparrow\downarrow$$

$$|\frac{3}{2}, \frac{1}{2}\rangle = \frac{1}{\sqrt{3}} (\downarrow\uparrow\uparrow + \uparrow\downarrow\uparrow + \uparrow\uparrow\downarrow)$$

Giving the spin $\frac{3}{2}$ states :

$$|\frac{3}{2}, \frac{3}{2}\rangle = \uparrow\uparrow\uparrow$$

$$|\frac{3}{2}, \frac{1}{2}\rangle = \frac{1}{\sqrt{3}} (\downarrow\uparrow\uparrow + \uparrow\downarrow\uparrow + \uparrow\uparrow\downarrow)$$

$$|\frac{3}{2}, -\frac{1}{2}\rangle = \frac{1}{\sqrt{3}} (\uparrow\downarrow\downarrow + \downarrow\uparrow\downarrow + \downarrow\downarrow\uparrow)$$

$$|\frac{3}{2}, -\frac{3}{2}\rangle = \downarrow\downarrow\downarrow$$

ALL SYMMETRIC under interchange of any two spins

★ For the spin-half states, first consider the case where the first two quarks are in a $|0, 0\rangle$ state.

$$|0, 0\rangle_{(12)} = \frac{1}{\sqrt{2}} (\uparrow\downarrow - \downarrow\uparrow)$$

$$|\frac{1}{2}, \frac{1}{2}\rangle_{(123)} = |0, 0\rangle_{(12)} |\frac{1}{2}, \frac{1}{2}\rangle = \frac{1}{\sqrt{2}} (\uparrow\downarrow\uparrow - \downarrow\uparrow\uparrow)$$

$$|\frac{1}{2}, -\frac{1}{2}\rangle_{(123)} = |0, 0\rangle_{(12)} |\frac{1}{2}, -\frac{1}{2}\rangle = \frac{1}{\sqrt{2}} (\uparrow\downarrow\downarrow - \downarrow\uparrow\downarrow)$$

ANTI-SYMMETRIC under interchange of 1 ↔ 2.

3-quark spin-half states can **ALSO** be formed from the state with the first two quarks in a **SYMMETRIC** spin wave-function.

Can construct a 3-particle $|\frac{1}{2}, \frac{1}{2}\rangle_{(123)}$ state from

$$|1, 0\rangle_{(12)}|\frac{1}{2}, \frac{1}{2}\rangle_{(3)} \quad \text{and} \\ |1, 1\rangle_{(12)}|\frac{1}{2}, -\frac{1}{2}\rangle_{(3)}$$

Taking a linear combination:

$$|\frac{1}{2}, \frac{1}{2}\rangle = a|1, 1\rangle|\frac{1}{2}, -\frac{1}{2}\rangle + b|1, 0\rangle|\frac{1}{2}, \frac{1}{2}\rangle$$

with $a^2 + b^2 = 1$. Act upon both sides with \hat{J}_+ :

$$\hat{J}_+|\frac{1}{2}, \frac{1}{2}\rangle = a(\hat{J}_+|1, 1\rangle)|\frac{1}{2}, -\frac{1}{2}\rangle + a|1, 1\rangle(\hat{J}_+|\frac{1}{2}, -\frac{1}{2}\rangle) \\ + b(\hat{J}_+|1, 0\rangle)|\frac{1}{2}, \frac{1}{2}\rangle + b|1, 0\rangle(\hat{J}_+|\frac{1}{2}, \frac{1}{2}\rangle) \\ 0 = a|1, 1\rangle|\frac{1}{2}, \frac{1}{2}\rangle + \sqrt{2}b|1, 1\rangle|\frac{1}{2}, \frac{1}{2}\rangle \\ a = -\sqrt{2}b$$

which with $a^2 + b^2 = 1$ implies:

$$a = \sqrt{\frac{2}{3}}, \quad b = -\sqrt{\frac{1}{3}}$$

Giving

$$|\frac{1}{2}, \frac{1}{2}\rangle = \sqrt{\frac{2}{3}}|1, 1\rangle|\frac{1}{2}, -\frac{1}{2}\rangle - \sqrt{\frac{1}{3}}|1, 0\rangle|\frac{1}{2}, \frac{1}{2}\rangle \\ |\frac{1}{2}, \frac{1}{2}\rangle = \frac{1}{\sqrt{6}}(2 \uparrow\uparrow\downarrow - \uparrow\downarrow\uparrow - \downarrow\uparrow\uparrow)$$

similarly

$$|\frac{1}{2}, -\frac{1}{2}\rangle = \frac{1}{\sqrt{6}}(2 \downarrow\downarrow\uparrow - \downarrow\uparrow\downarrow - \uparrow\downarrow\downarrow)$$

3 QUARK SPIN WAVE-FUNCTIONS

①

$$\frac{3}{2}$$

$$|\frac{3}{2}, \frac{3}{2}\rangle = \uparrow\uparrow\uparrow$$

$$|\frac{3}{2}, \frac{1}{2}\rangle = \frac{1}{\sqrt{3}}(\downarrow\uparrow\uparrow + \uparrow\downarrow\uparrow + \uparrow\uparrow\downarrow)$$

$$|\frac{3}{2}, -\frac{1}{2}\rangle = \frac{1}{\sqrt{3}}(\uparrow\downarrow\downarrow + \downarrow\uparrow\downarrow + \downarrow\downarrow\uparrow)$$

$$|\frac{3}{2}, -\frac{3}{2}\rangle = \downarrow\downarrow\downarrow$$

SYMMETRIC under interchange of **any** two quarks

②

$$\frac{1}{2}$$

$$|\frac{1}{2}, \frac{1}{2}\rangle = \frac{1}{\sqrt{6}}(2\uparrow\uparrow\downarrow - \uparrow\downarrow\uparrow - \downarrow\uparrow\uparrow)$$

$$|\frac{1}{2}, -\frac{1}{2}\rangle = \frac{1}{\sqrt{6}}(2\downarrow\downarrow\uparrow - \downarrow\uparrow\downarrow - \uparrow\downarrow\downarrow)$$

SYMMETRIC under interchange of **1 ↔ 2**

③

$$\frac{1}{2}$$

$$|\frac{1}{2}, \frac{1}{2}\rangle = \frac{1}{\sqrt{2}}(\uparrow\downarrow - \downarrow\uparrow)\uparrow$$

$$|\frac{1}{2}, -\frac{1}{2}\rangle = \frac{1}{\sqrt{2}}(\uparrow\downarrow - \downarrow\uparrow)\downarrow$$

ANTI-SYMMETRIC under interchange of **1 ↔ 2**

$\psi_{\text{spin}}\psi_{\text{flavour}}$ **must be symmetric** under interchange of **any two quarks**.

Consider 3 cases:

① Quarks all SAME Flavour: uuu,ddd,sss

- ★ ψ_{flavour} is **SYMMETRIC** under interchange of **any** two quarks.
- ★ REQUIRE ψ_{spin} to be **SYMMETRIC** under interchange of **any** two quarks.
- ★ ONLY satisfied by SPIN- $\frac{3}{2}$ states.
- ★ no uuu, ddd, sss, SPIN- $\frac{1}{2}$ baryons with $L = 0$

3 SPIN- $\frac{3}{2}$ states : uuu,ddd,sss.

② Two quarks have same Flavour: ddu,uud,..

- ★ For the like quarks, ψ_{flavour} is **SYMMETRIC**.
- ★ REQUIRE ψ_{spin} to be **SYMMETRIC** under interchange of **LIKE** quarks **1** \leftrightarrow **2**.
- ★ satisfied by SPIN- $\frac{3}{2}$ and SPIN- $\frac{1}{2}$

6 SPIN- $\frac{3}{2}$ and **6 SPIN- $\frac{1}{2}$** states: uud, uus, ddu, dds, ssu, ssd

For example: PROTON wave-function ($s_z = \frac{1}{2}$):

$$p \uparrow = \frac{1}{\sqrt{6}} (2u \uparrow u \uparrow d \downarrow - u \uparrow u \downarrow d \uparrow - u \downarrow u \uparrow d \uparrow)$$

The above form for the proton wavefunction is sufficient to derive masses and magnetic moments, however, note that the fully symmetrized wavefunction includes cyclic permutations:

$$\frac{1}{\sqrt{18}} (2u \uparrow u \uparrow d \downarrow - u \uparrow u \downarrow d \uparrow - u \downarrow u \uparrow d \uparrow + \\ 2d \downarrow u \uparrow u \uparrow - d \uparrow u \uparrow u \downarrow - d \uparrow u \downarrow u \uparrow + \\ 2u \uparrow d \downarrow u \uparrow - u \uparrow d \uparrow u \downarrow - u \downarrow d \uparrow u \uparrow)$$

③ All Quarks have DIFFERENT Flavour: uds

Two possibilities for (ud) part:

i) FLAVOUR SYMMETRIC $\frac{1}{\sqrt{2}}(ud + du)$

★ require spin wave-function to be SYMMETRIC under interchange of ud

★ satisfied by SPIN- $\frac{3}{2}$ and SPIN- $\frac{1}{2}$ states

→ ONE SPIN- $\frac{3}{2}$ uds state

→ ONE SPIN- $\frac{1}{2}$ uds state

ii) FLAVOUR ANTI-SYMMETRIC $\frac{1}{\sqrt{2}}(ud - du)$

★ require spin wave-function to be ANTI-SYMMETRIC under interchange of ud

★ only satisfied by SPIN- $\frac{1}{2}$ state

→ ONE SPIN- $\frac{1}{2}$ uds state

In total **TEN** (3+6+1) SPIN- $\frac{3}{2}$ states with the required overall symmetry and **EIGHT** (0+6+2) SPIN- $\frac{1}{2}$ states

Quark Model predicts Baryons appear in **DECUPLETS** of SPIN- $\frac{3}{2}$ and **OCTETS** of SPIN- $\frac{1}{2}$

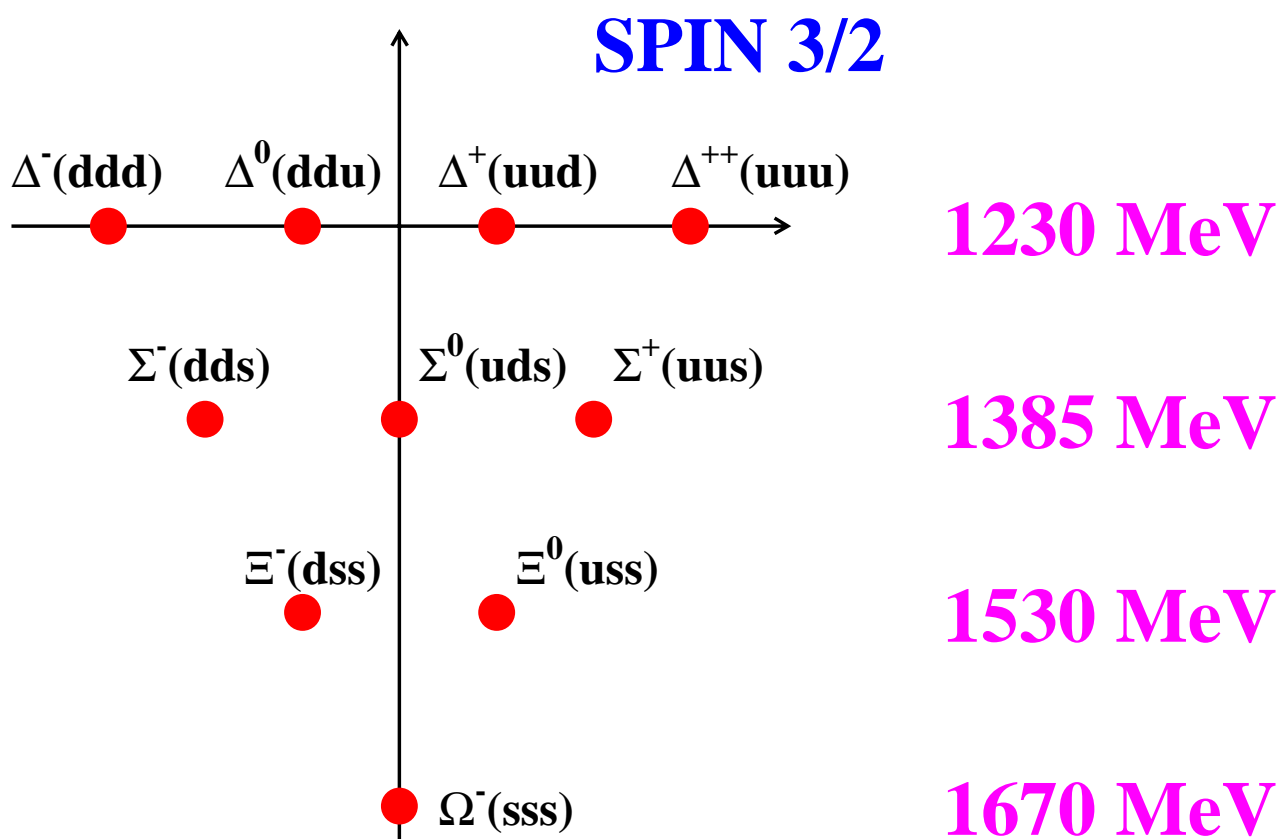
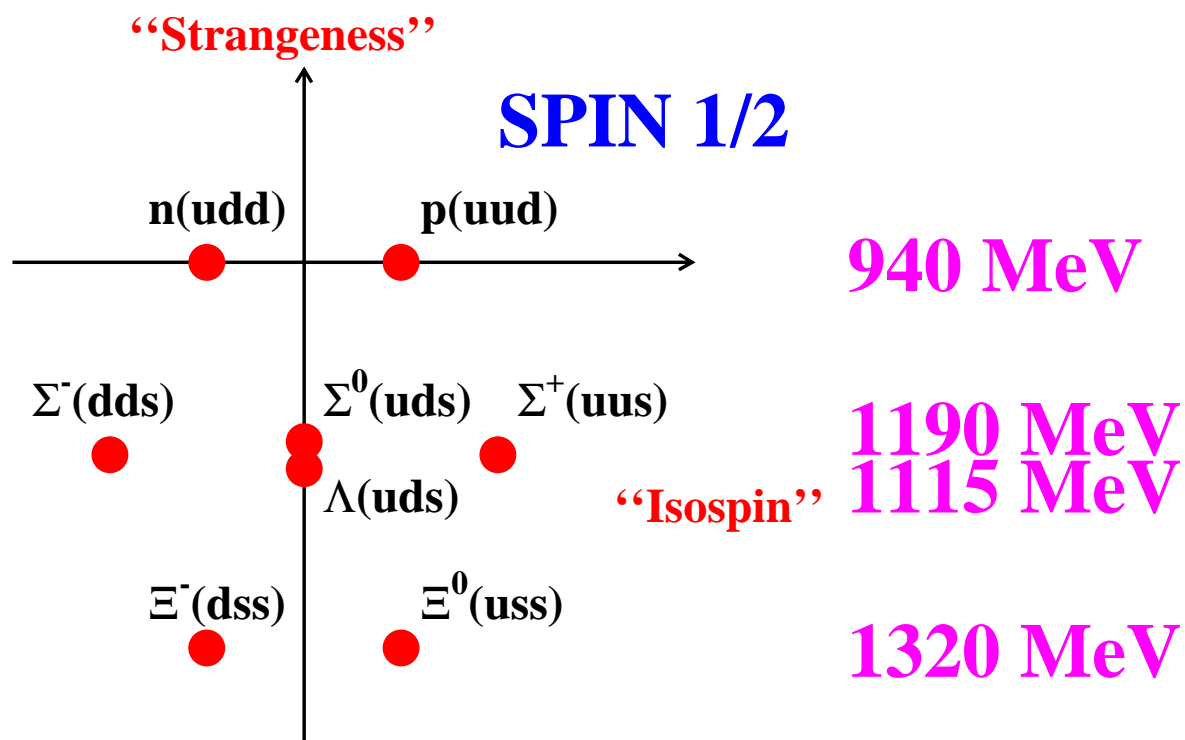

BARYON MASS FORMULA (L=0)

$$M_{qqq} = m_1 + m_2 + m_3 + A' \left(\frac{\tilde{S}_1 \cdot \tilde{S}_2}{m_1 m_2} + \frac{\tilde{S}_1 \cdot \tilde{S}_3}{m_1 m_3} + \frac{\tilde{S}_2 \cdot \tilde{S}_3}{m_2 m_3} \right)$$

where A' is a constant

EXAMPLE $m_1 = m_2 = m_3 = m_q$

$$\text{here } M_{qqq} = 3m_q + A' \sum_{i < j} \frac{\tilde{S}_i \cdot \tilde{S}_j}{m_q^2}$$

$$\tilde{S}^2 = (\tilde{S}_1 + \tilde{S}_2 + \tilde{S}_3)^2$$

$$\tilde{S}^2 = \tilde{S}_1^2 + \tilde{S}_2^2 + \tilde{S}_3^2 + 2 \sum_{i < j} \tilde{S}_i \cdot \tilde{S}_j$$

$$2 \sum_{i < j} \tilde{S}_i \cdot \tilde{S}_j = S(S + 1) - 3 \frac{1}{2} \left(\frac{1}{2} + 1 \right)$$

$$2 \sum_{i < j} \tilde{S}_i \cdot \tilde{S}_j = S(S + 1) - \frac{9}{4}$$

$$\sum_{i < j} \tilde{S}_i \cdot \tilde{S}_j = -\frac{3}{4} \quad J = \frac{1}{2}$$

$$\sum_{i < j} \tilde{S}_i \cdot \tilde{S}_j = +\frac{3}{4} \quad J = \frac{3}{2}$$

e.g. proton(uud) versus Δ (uud)

$$m_p = 3m_u - \frac{3}{4} \frac{A'}{m_u^2}$$

$$m_\Delta = 3m_u + \frac{3}{4} \frac{A'}{m_u^2}$$

Again try different values of $m_{u/d}$, m_s and A' and try to reproduce the observed values.

Baryon	Mass/MeV	
	Predicted	Experiment
p/n	939	939
Λ	1116	1114
Σ	1193	1179
Ξ	1318	1327
Δ	1232	1239
Σ^*	1384	1381
Ξ^*	1533	1529
Ω	1672	1682

Excellent agreement using: $m_u = m_d = 363 \text{ MeV}$,

$m_s = 538 \text{ MeV}$,

$A' = 0.026 \text{ GeV}^3$.

QCD predicts $A' = A/2$ where A is the corresponding constant in the meson mass formula.

Recall $A = 0.06 \text{ GeV}^3$ provided a good description of meson masses.

Baryon Magnetic Moments

Assume the bound quarks within baryons behave as **DIRAC** point-like SPIN-1/2 particles with fractional charge, q_q . Then quarks will have magnetic dipole moments:

$$\hat{\mu}_q = \frac{q_q}{m_q} \hat{S}$$

where m_q is the quark mass.

Magnitude of the magnetic dipole moment:

$$\mu_q = \langle q \uparrow | \frac{q_q}{m_q} \hat{S} | q \uparrow \rangle$$

$$\text{with } \hat{S} | q \uparrow \rangle = \frac{1}{2} \hbar | q \uparrow \rangle$$

$$\text{giving } \mu_q = \frac{q_q \hbar}{2m_q}$$

$$\mu_u = \frac{2}{3} \frac{e\hbar}{2m_u}, \mu_d = -\frac{1}{3} \frac{e\hbar}{2m_d}, \mu_s = -\frac{1}{3} \frac{e\hbar}{2m_s}$$

For quarks bound within a **L=0** baryon, **X**, the baryon magnetic moment is the expectation value of the sum of the individual quark magnetic moments.

$$\hat{\mu}_B = \frac{q_1}{m_1} \hat{S}_1 + \frac{q_2}{m_2} \hat{S}_2 + \frac{q_3}{m_3} \hat{S}_2$$

$$\mu_X = \langle X \uparrow | \hat{\mu}_B | X \uparrow \rangle$$

where $|X \uparrow\rangle$ is the baryon wave-function for the spin up state.

For a spin-up proton:

$$\begin{aligned}
 p \uparrow &= \frac{1}{\sqrt{6}}(2u \uparrow u \uparrow d \downarrow - (u \uparrow u \downarrow + u \downarrow u \uparrow)d \uparrow) \\
 \Rightarrow \mu_p &= \frac{1}{6} \langle (2 \uparrow \uparrow \downarrow - (\uparrow \downarrow + \downarrow \uparrow) \uparrow) | \hat{\mu}_1 + \hat{\mu}_2 + \hat{\mu}_3 | (2 \uparrow \uparrow \downarrow - (\uparrow \downarrow + \downarrow \uparrow) \uparrow) \rangle
 \end{aligned}$$

Consider the contribution from quark 1 (an up-quark):

$$\begin{aligned}
 &\frac{1}{6} \langle (2 \uparrow \uparrow \downarrow - (\uparrow \downarrow + \downarrow \uparrow) \uparrow) | \hat{\mu}_1 | (2 \uparrow \uparrow \downarrow - (\uparrow \downarrow + \downarrow \uparrow) \uparrow) \rangle \\
 &= \frac{1}{6} \langle (2 \uparrow \uparrow \downarrow - (\uparrow \downarrow + \downarrow \uparrow) \uparrow) | (2\mu_1 \uparrow \uparrow \downarrow - (\mu_1 \uparrow \downarrow - \mu_1 \downarrow \uparrow) \uparrow) \rangle \\
 &= \frac{2}{3} \mu_1 = \frac{2}{3} \mu_u = \frac{4}{9} \frac{e\hbar}{2m_u}
 \end{aligned}$$

Summing over the other contributions gives:

$$\begin{aligned}
 \mu_p &= \frac{4}{3} \mu_u - \frac{1}{3} \mu_d = \frac{4}{9} \frac{e\hbar}{2m_u} + \frac{4}{9} \frac{e\hbar}{2m_u} + \frac{1}{9} \frac{e\hbar}{2m_d} \\
 &= \frac{e\hbar}{2m_{u/d}} = \frac{m_p}{m_{u/d}} \mu_N
 \end{aligned}$$

where μ_N is the NUCLEAR MAGNETON $\mu_N = e\hbar/2m_p$

Repeat for other (L=0) Baryons, PREDICT

$$\frac{\mu_n}{\mu_p} = -\frac{2}{3}$$

compared to the experimentally measured value of
-0.685

Baryon	μ_B in Quark Model	Predicted [μ_N]	Experiment [μ_N]
p	$\frac{4}{3}\mu_u - \frac{1}{3}\mu_d$	+2.79	+2.793
n	$\frac{4}{3}\mu_d - \frac{1}{3}\mu_u$	-1.86	-1.913
Λ	μ_s	-0.61	-0.614 ± 0.005
Σ^+	$\frac{4}{3}\mu_u - \frac{1}{3}\mu_s$	+2.68	$+2.46 \pm 0.01$
Ξ^0	$\frac{4}{3}\mu_s - \frac{1}{3}\mu_u$	-1.44	-1.25 ± 0.014
Ξ^-	$\frac{4}{3}\mu_s - \frac{1}{3}\mu_d$	-0.51	-0.65 ± 0.01
Ω^-	$3\mu_s$	-1.84	-2.02 ± 0.05

Impressive agreement with data using

$$m_u = m_d = 336 \text{ MeV and}$$

$$m_s = 509 \text{ MeV.}$$

(see Question 5 on the problem sheet)

SUMMARY

- ★ Baryons and mesons are complicated objects.
- ★ However, the Quark model can be used to make predictions for masses/magnetic moments.
- ★ The predictions give reasonably consistent values for the constituent quark masses.

	$m_{u/d}$	m_s
Meson Masses	310 MeV	483 MeV
Baryon Masses	363 MeV	538 MeV
Baryon mag. moms.	336 MeV	510 MeV

$$m_u \approx 335 \text{ MeV}$$

$$m_d \approx 335 \text{ MeV}$$

$$m_s \approx 510 \text{ MeV}$$

- ★ What about the HEAVY quarks (charm, bottom, top)....

Discovery of the J/ψ

★ 1974 : Discovery of a **NARROW RESONANCE** in e^+e^- collisions at $\sqrt{s} \approx 3.1$ GeV

Observe resonances R_{μ} at low \sqrt{s} - many "bumps"

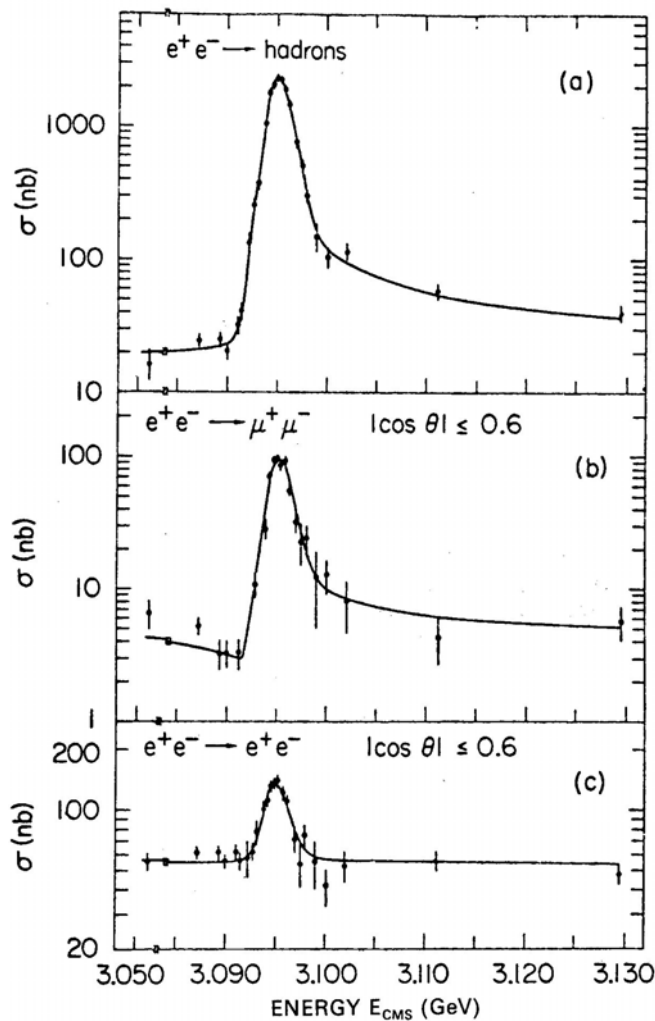
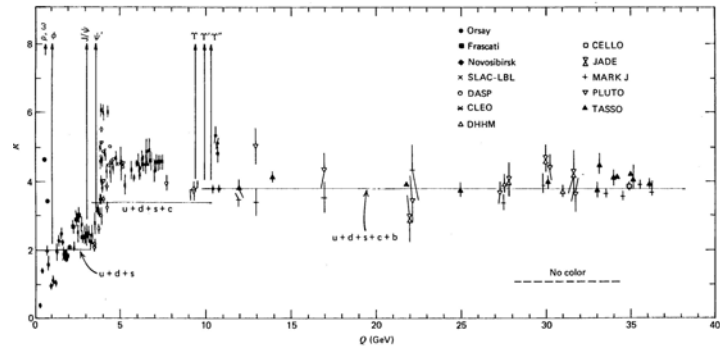

$e^+e^- \rightarrow \text{hadrons}$

$J/\psi(3097)$

$e^+e^- \rightarrow \mu^+\mu^-$

$e^+e^- \rightarrow e^+e^-$

Observed width, ~ 3 MeV, all due to experimental resolution ! Actual **WIDTH**, $\Gamma_{J/\psi} \sim 87$ keV.

Zoom in to the **CHARMONIUM** ($c\bar{c}$) region, i.e.

$$\sqrt{s} \sim 2m_c$$

mass of charm quark, $m_c = 1.5 \text{ GeV}$

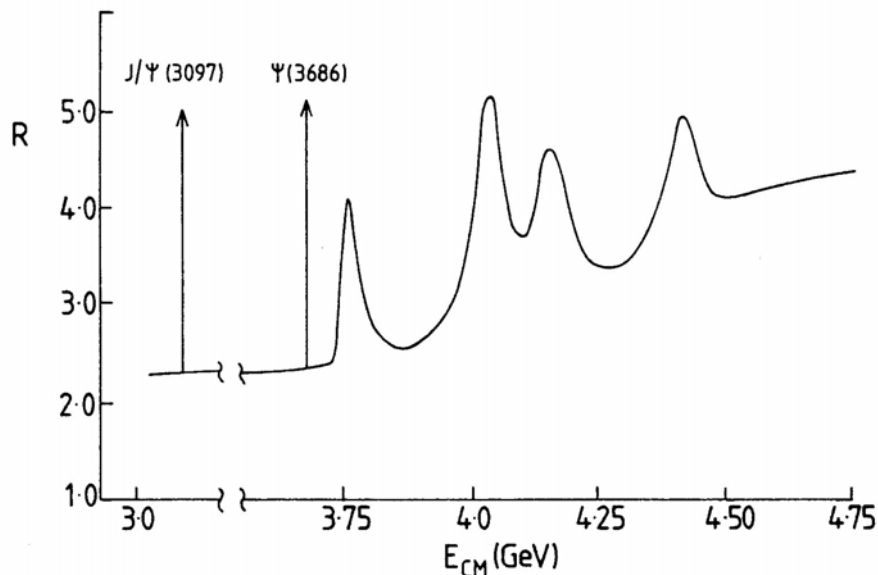

Resonances due to formation of **BOUND** unstable $c\bar{c}$ states. The lowest energy of these is the narrow J/ψ state.

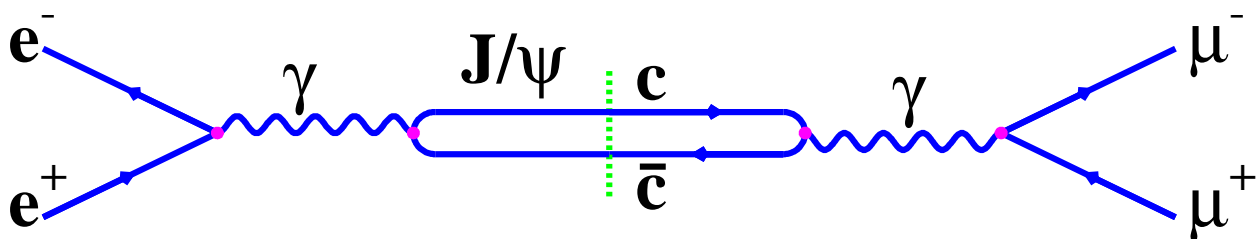

The particle physics of decaying particles:

- ★ Particle Lifetimes
- ★ Decay Widths
- ★ Partial Widths
- ★ Resonances

i.e. the physics of $e^+e^- \rightarrow Z^0$.

Much of this will be familiar from Nuclear Physics

Particle Decay

Most Particles are transient beings - only the privileged few live forever (e^- , u , d , γ , ..). Transition rate **Undecayed** \rightarrow **decayed** given by Fermi's Golden Rule:

$$T_{fi} = 2\pi |M_{fi}|^2 \rho(E_f)$$

T_{fi} is the transition probability per unit time. **Note**, previously used Γ_{fi} for transition probability.

Start with N particles, in time dt , $N T_{fi} dt$ will decay:

$$\begin{aligned} dN &= -N T_{fi} dt \\ \int \frac{1}{N} dN &= - \int T_{fi} dt \\ N &= N_0 e^{-T_{fi} t} = N_0 e^{-t/\tau} \end{aligned}$$

where τ is the mean lifetime

$$\tau = \frac{1}{T_{fi}}$$

Finite lifetime \Rightarrow **UNCERTAIN** energy ΔE

$$\Delta E \Delta t \sim \hbar$$

Decaying states do not correspond to a single energy - they have a width, ΔE

$$\begin{aligned} \Delta E \tau &\sim \hbar \\ \Delta E &\sim \hbar / \tau = \hbar T_{fi} \end{aligned}$$

The **WIDTH**, ΔE , of a particle state is:

- inversely proportional to the **lifetime** τ
- **EQUAL** to the transition rate T_{fi} using **Natural Units**

Decaying States \rightarrow Resonances

QM description of decaying states

Consider a state with energy E_0 and lifetime τ , need to modify the time dependent part of the wave-function ($E_0 = \hbar\omega$):

$$\psi(t) = \psi_0 e^{(-iE_0 t)} \rightarrow \psi_0 e^{(-iE_0 t)} e^{(-\frac{t}{2\tau})}$$

$$\psi^* \psi = \psi_0^* \psi_0 e^{(-\frac{t}{\tau})}$$

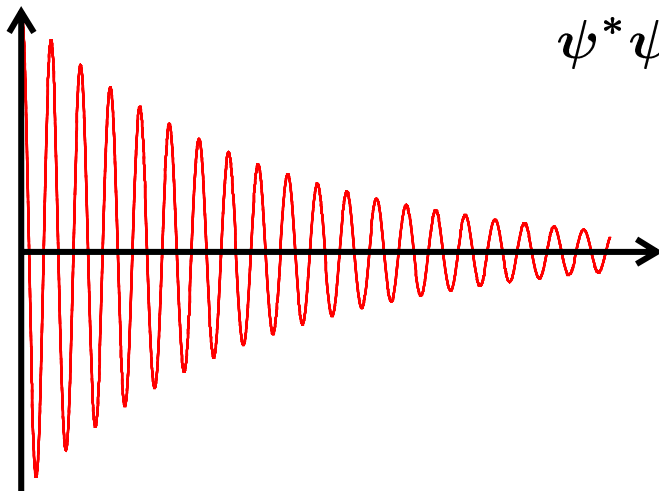

i.e. probability density decays exponentially as required.

The frequencies present in the wave-function are given by the Fourier transform of $\psi(t)$

$$\begin{aligned} f(\omega) = f(E) &= \int_0^{\infty} \psi_0 e^{-t(iE_0 + \frac{1}{2\tau})} e^{(iEt)} dt \\ &= \int_0^{\infty} \psi_0 e^{-t(i(E_0 - E) + \frac{1}{2\tau})} dt \\ &= \frac{\psi_0}{(E_0 - E) - i/(2\tau)} \end{aligned}$$

Probability of finding state with energy $E = f(E)^* f(E)$

$$\frac{\psi_0^* \psi_0}{(E_0 - E)^2 + \frac{1}{4\tau^2}}$$

Finite lifetime \Leftrightarrow uncertain energy

Cross-section for producing the decaying state has this energy dependence - *i.e.* **RESONANT** when $E = E_0$

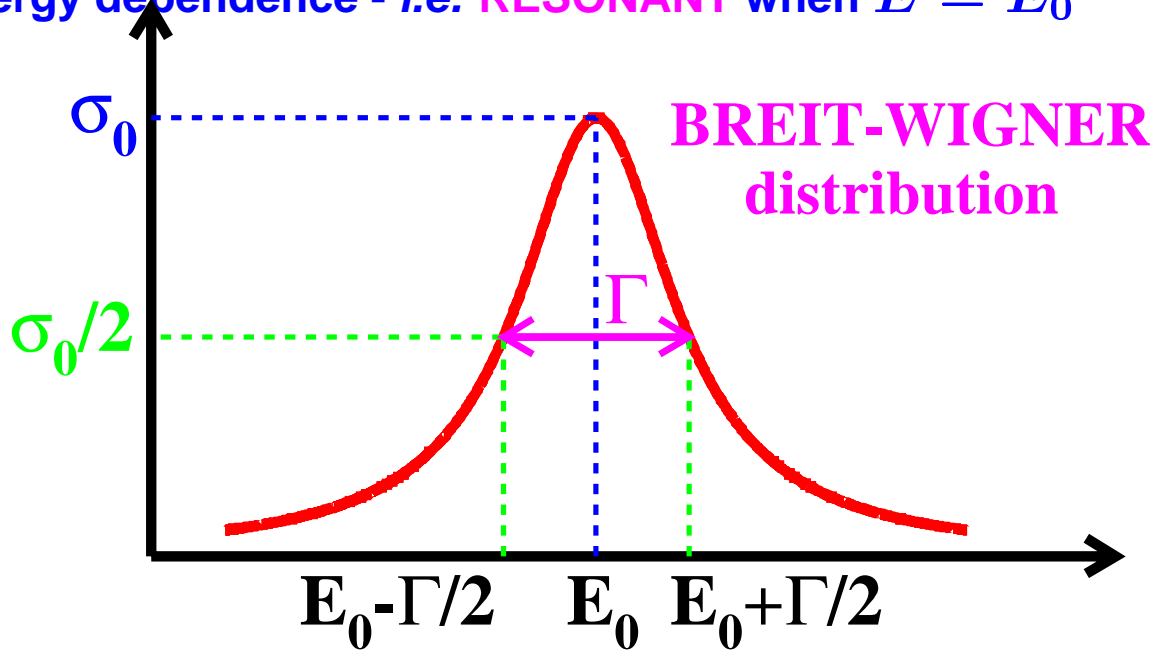

Consider full-width at half-maximum amplitude (FWHM)

$$\sigma(E) \propto \frac{1}{(E_0 - E)^2 + \frac{1}{4\tau^2}}$$

$$\sigma(E = E_0) \propto 4\tau^2$$

$$\sigma(E) = \frac{\sigma_0}{4\tau^2} \frac{1}{(E_0 - E)^2 + \frac{1}{4\tau^2}}$$

$$\begin{aligned} \text{now } \sigma\left(E_0 \pm \frac{1}{2\tau}\right) &= \frac{\sigma_0}{4\tau^2} \frac{1}{\left(E_0 - E_0 \pm \frac{1}{2\tau}\right)^2 + \frac{1}{4\tau^2}} \\ &= \frac{\sigma_0}{2} \end{aligned}$$

So FWHM corresponds to $\pm \frac{1}{2\tau}$, or **TOTAL WIDTH**

$$\Gamma = \frac{1}{\tau} = T_{fi}$$

(using Natural units)

Partial Decay Widths

Particles with more than one **DECAY MODE**, e.g.

- ★ $J/\psi \rightarrow \text{hadrons}$ $(87.7 \pm 0.5 \%)$
- ★ $J/\psi \rightarrow e^+e^-$ $(5.9 \pm 0.1 \%)$
- ★ $J/\psi \rightarrow \mu^+\mu^-$ $(5.9 \pm 0.1 \%)$

The numbers in brackets are the decay **BRANCHING FRACTIONS** i.e. 87.7 % of the time $J/\psi \rightarrow \text{hadrons}$

Transition rate for **DECAY MODE** k :

$$T_{fi}^k = 2\pi |M_{J/\psi \rightarrow k}|^2 \rho(E)$$

Total decay rate $J/\psi \rightarrow \text{anything}$:

$$T_{fi}^{\text{total}} = \sum_k T_{fi}^k$$

THIS determines the lifetime,

$$\tau = \frac{1}{T_{fi}^{\text{total}}}$$

The **TOTAL WIDTH** of a particle state, Γ :

$$\Gamma = \hbar T_{fi}^{\text{total}} = \hbar \sum_k T_{fi}^k$$

Define the **PARTIAL WIDTHS**, Γ_k

$$\Gamma_k = \hbar T_{fi}^k$$

$$\Gamma = \sum_k \Gamma_k$$

Finally, **BRANCHING FRACTION** f_k :

$$f_k = \frac{T_{fi}^k}{T_{fi}^{\text{total}}} = \frac{\Gamma_k}{\Gamma}$$

Partial Widths : Example J/ψ

LIFETIME:

- ★ J/ψ has lifetime $\tau_{J/\psi} = 7.6 \times 10^{-21}$ s
- ★ immeasurably small !

TOTAL WIDTH:

$$\begin{aligned}\Gamma_{J/\psi} &= \frac{\hbar}{\tau_{J/\psi}} \\ &= 87 \pm 5 \text{ keV}\end{aligned}$$

BRANCHING FRACTIONS:

- ★ $J/\psi \rightarrow \text{hadrons}$ (87.7 \pm 0.5 %)
- ★ $J/\psi \rightarrow e^+e^-$ (5.9 \pm 0.1 %)
- ★ $J/\psi \rightarrow \mu^+\mu^-$ (5.9 \pm 0.1 %)

PARTIAL WIDTHS

$$\begin{aligned}e.g. \quad \Gamma_{J/\psi \rightarrow e^+e^-} &= \Gamma_{J/\psi} \times 0.059 \\ &= 5 \text{ keV} \\ \Gamma_{J/\psi \rightarrow \mu^+\mu^-} &= 5 \text{ keV} \\ \Gamma_{J/\psi \rightarrow \text{hadrons}} &= 77 \text{ keV}\end{aligned}$$

COMMON MISCONCEPTIONS:

- ★ Different partial widths for the decay modes **DOES NOT** mean different widths for the resonance curve. This is determined by the lifetime (i.e. the TOTAL width).
- ★ Different partial widths do not imply a different constant in the exponential lifetime expression for $J/\psi \rightarrow e^+e^-$ - only the total decay rate matters

Resonant Production

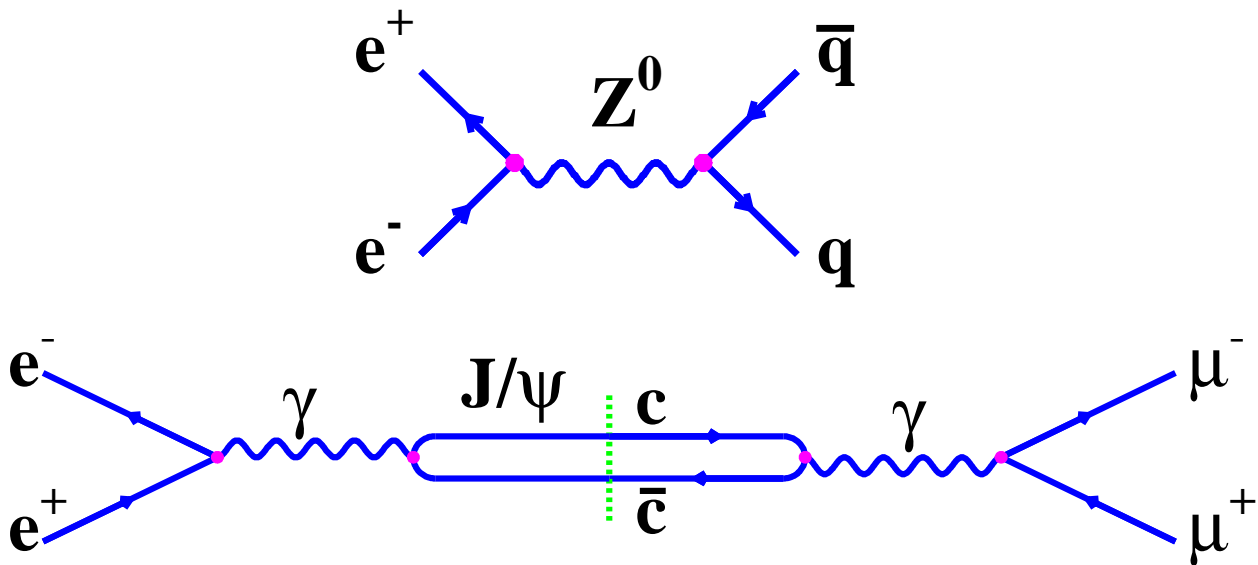

Cross section for particle scattering/annihilation via an intermediate **DECAYING** state, $i \rightarrow j \rightarrow f$. Start from

$$\sigma = 2\pi |M|^2 \rho(E)$$

Previously (**handout II**) used time-ordered PT and looked at the terms in the perturbation expansion:

$$M_{fj} \frac{1}{E_i - E_j} M_{ji}$$

Sum over all time-orderings to give propagator (Feynman diagrams).

$$M_{fj} \frac{1}{q^2 - m^2} M_{ji}$$

For a **DECAYING** intermediate state

$$\psi(t) = \psi_0 e^{(-iEt)} \rightarrow \psi_0 e^{(-iEt)} e^{(-\frac{t}{2\tau})}$$

$$i.e. \quad E \rightarrow \left(E - \frac{i}{2\tau} \right) = \left(E - \frac{i\Gamma}{2} \right)$$

Make this substitution for E_j in the perturbation expansion.

$$M_{fj} \frac{1}{E_i - E_j} M_{ji} \rightarrow M_{fj} \frac{1}{E_i - E_j + i\Gamma/2} M_{ji}$$

In the limit $\Gamma^2 \ll m^2$ the propagator for a DECAYING state becomes:

$$\frac{1}{q^2 - m^2} \rightarrow \frac{1}{q^2 - m^2 + im\Gamma}$$

EXAMPLE: (NON-EXAMINABLE)

$$e^+e^- \rightarrow J/\psi \rightarrow \mu^+\mu^-$$

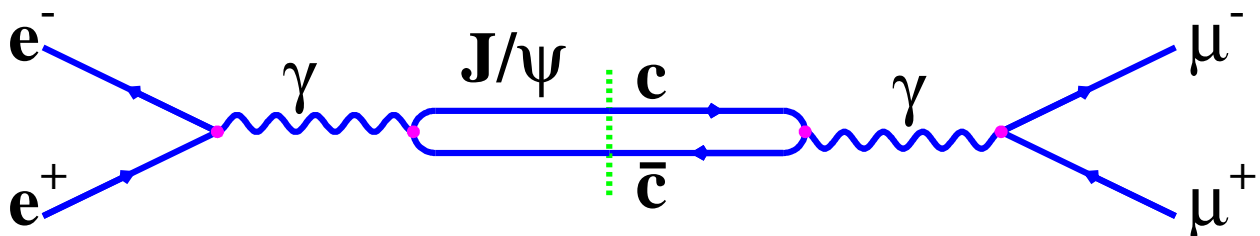

In centre-of-mass system ($q^2 = E^2$) would expect cross section to be of form:

$$\sigma \sim |M_{e^+e^- \rightarrow \psi}|^2 \frac{1}{(E^2 - m_\psi^2)^2 + \Gamma_\psi^2 m_\psi^2} |M_{\psi \rightarrow \mu^+\mu^-}|^2 \rho(E_\mu)$$

First, note partial width for $J/\psi \rightarrow \mu^+\mu^-$:

$$\Gamma_{\mu\mu} \sim |M_{\psi \rightarrow \mu^+\mu^-}|^2 \rho(E_\mu)$$

$$\text{giving } \sigma \sim |M_{e^+e^- \rightarrow \psi}|^2 \frac{1}{(E^2 - m_\psi^2)^2 + \Gamma_\psi^2 m_\psi^2} \Gamma_{\mu\mu}$$

Partial width for $J/\psi \rightarrow e^+e^-$:

$$\Gamma_{ee} \sim |M_{\psi \rightarrow e^+e^-}|^2 \rho(E_e)$$

$$\text{with } \rho(E_e) = 4\pi \frac{E_e^2}{(2\pi)^3}$$

giving $|M_{\psi \rightarrow e^+e^-}|^2 \sim \frac{\pi \Gamma_{ee}}{E_e^2}$

BUT $|M_{\psi \rightarrow e^+e^-}|^2 = |M_{e^+e^- \rightarrow \psi}|^2$

$$\sigma = \frac{\pi}{E_e^2} \frac{4m_\psi^2 \Gamma_{ee} \Gamma_{\mu\mu}}{(E^2 - m_\psi^2)^2 + m_\psi^2 \Gamma_\psi^2}$$

(The factor $4m_\psi$ comes from the relativistic wave-function normalization)

Need to sum over possible SPIN states of intermediate particle and average over initial electron states. Introduces SPIN-FACTOR

$$g = \frac{2J + 1}{(2S_1 + 1)(2S_2 + 1)}$$

where J is the ANGULAR MOMENTUM of the resonance, S_1, S_2 are the SPINS of the initial particles.

$$\sigma = g \frac{4\pi m_\psi^2}{E_e^2} \frac{\Gamma_{ee} \Gamma_{\mu\mu}}{(E^2 - m_\psi^2)^2 + m_\psi^2 \Gamma_\psi^2}$$

Which for $\Gamma^2 \ll m_\psi^2$ may be written in the more conventional form:

$$\sigma = g \frac{\pi}{E_e^2} \frac{\Gamma_{ee} \Gamma_{\mu\mu}}{(E - m_\psi)^2 + \Gamma_\psi^2 / 4}$$

THE BREIT-WIGNER RESONANCE FORMULA

NOTE: E_e is the energy of a SINGLE initial state particle.

(see Question 6 on the problem sheet)

Charmonium

- ★ In e^+e^- collisions observe $c\bar{c}$ bound states as resonances, e.g. $e^+e^- \rightarrow J/\psi \rightarrow \mu^+\mu^-$.
- ★ Only produce $c\bar{c}$ bound states with same J^{PC} as photon 1^{--} .

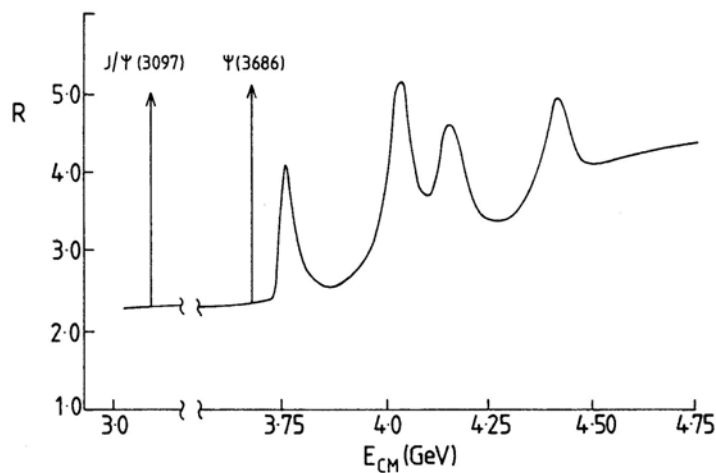

Only directly produce 1^{--} states in e^+e^- collisions

- ★ Other states observed via DECAY e.g.

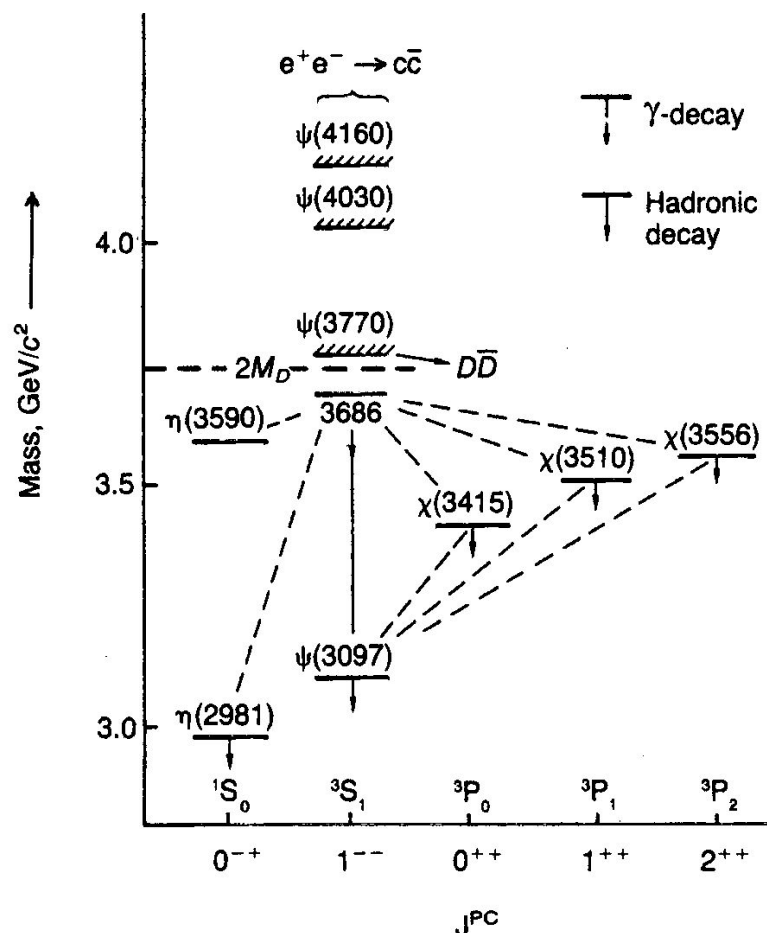

★ Photonic decays e.g.

$$\psi(3685) \rightarrow \chi + \gamma$$

$$\chi \rightarrow J/\psi(3097) + \gamma$$

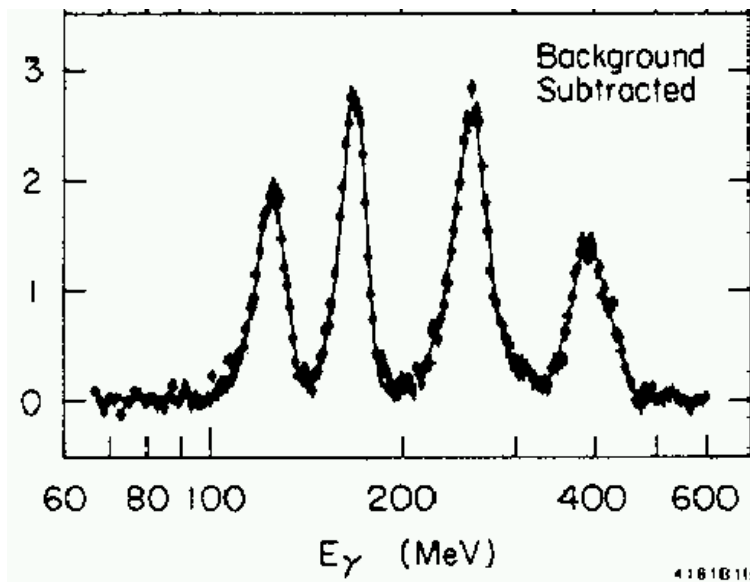

Crystal Ball Expt. 1982

$$e^+e^- \rightarrow \psi(3686)$$

First 3 peaks:

$$\psi(3686) \rightarrow \chi(3556)\gamma$$

$$\psi(3686) \rightarrow \chi(3510)\gamma$$

$$\psi(3686) \rightarrow \chi(3415)\gamma$$

Fourth peak:

$$\chi(3556) \rightarrow J/\psi(3097)\gamma$$

$$\chi(3510) \rightarrow J/\psi(3097)\gamma$$

★ Knowing the $c\bar{c}$ levels provides a probe of the QCD potential:

★ Because QCD is a theory of a strong confining force (self-interacting gluons) it is **VERY** difficult to calculate the exact form of the QCD potential from first principles.

★ However, it is possible to experimentally 'determine' the QCD potential by finding an appropriate form which gives the observed charmonium states.

★ In practice one finds that

$$V_{QCD} = -\frac{4}{3} \frac{\alpha_S}{r} + kr$$

with $\alpha_S = 0.2$ and $k = 1 \text{ GeV fm}^{-1}$ provides a good description of the **EXPERIMENTALLY OBSERVED** levels in the charmonium system.

★ yet to explain why low energy states are so narrow....

Why is the J/ψ so narrow ?

1^3S_1	$\psi(3097)$	$\Gamma \approx 0.09 \text{ MeV}$
2^3S_1	$\psi(3685)$	$\Gamma \approx 0.28 \text{ MeV}$
3^3S_1	$\psi(3770)$	$\Gamma \approx 25 \text{ MeV}$
4^3S_1	$\psi(4040)$	$\Gamma \approx 52 \text{ MeV}$

★ Width depends on whether the decay to lightest mesons containing c quarks is kinematically possible: $D^- (d\bar{c})$, $D^+ (c\bar{d})$

$$m_{D^\pm} = 1869.4 \pm 0.5 \text{ MeV}$$

IF $m(\psi) > 2m(D)$

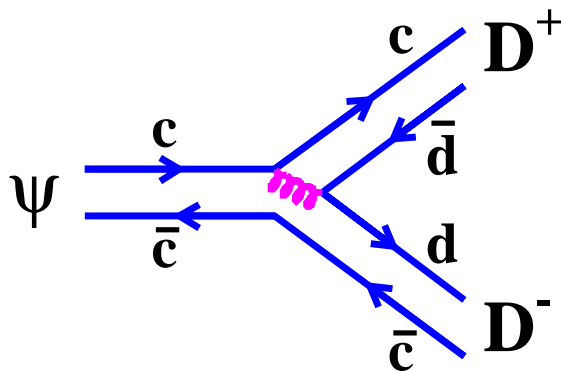

$\psi \rightarrow D^+ D^-$ ALLOWED
 'ordinary' STRONG DECAY
 \Rightarrow large width

IF $m(\psi) < 2m(D)$

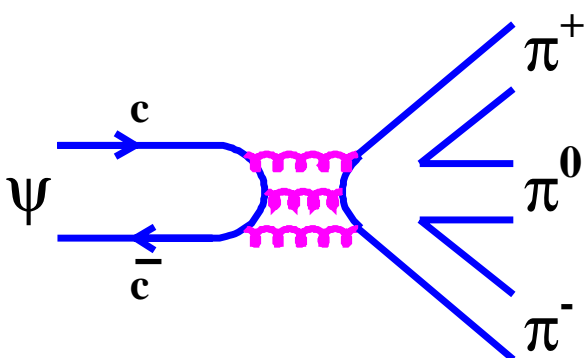

ZWEIG RULE

Unconnected lines in the quark diagram lead to SUPPRESSION of the decay amplitude
 \Rightarrow narrow width

Requires at least 3 Gluons $\Gamma \propto \alpha_s^6$,

i.e. suppressed \Rightarrow **NARROW**

Bottomonium

- ★ In 1977 $\Upsilon(9460)$ state discovered
- ★ lowest energy 3S_1 bound $b\bar{b}$ state
- ★ $\Rightarrow m_b \sim 4.7 \text{ GeV}$

Similar properties to the ψ

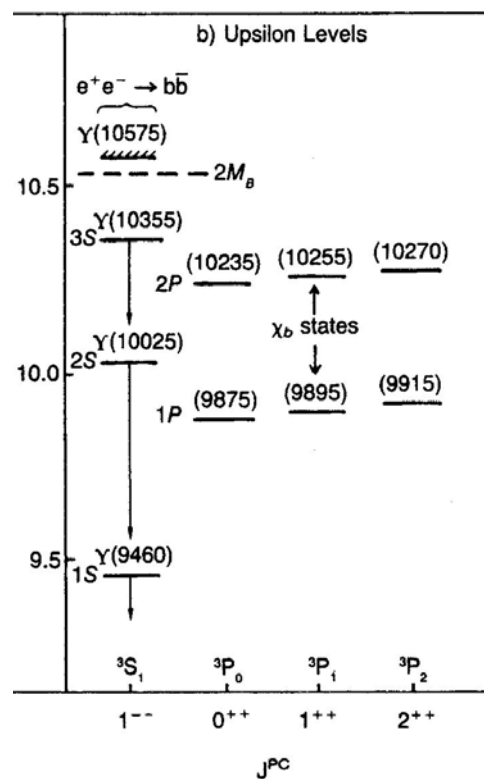

- ★ Bottomonium spectrum well described by same QCD potential as used for charmonium
- ★ Evidence that the QCD potential does not depend on Quark type

Very similar properties to charmonium

Summary

$$m_u \approx 335 \text{ MeV}$$

$$m_d \approx 335 \text{ MeV}$$

$$m_s \approx 510 \text{ MeV}$$

$$m_c \approx 1.5 \text{ GeV}$$

$$m_b \approx 4.5 \text{ GeV}$$

$$m_t \approx 175 \text{ GeV}$$

..and have discussed decaying intermediate states.

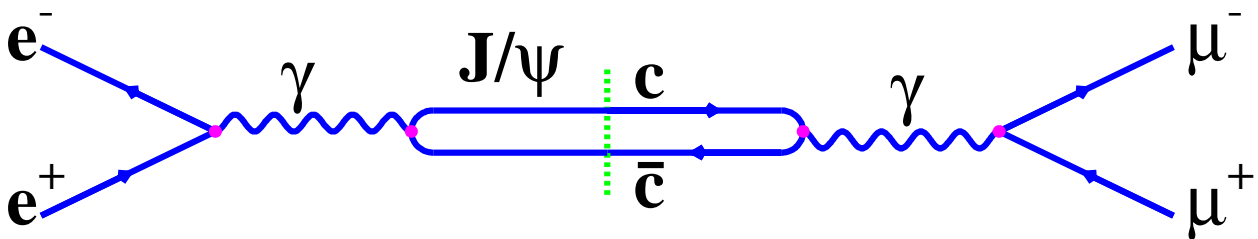

and hopefully have a better understanding of the Breit-Wigner formula.

$$\sigma = g \frac{\pi}{E_e^2} \frac{\Gamma_{ee}\Gamma_{\mu\mu}}{(E - m_\psi)^2 + \Gamma_\psi^2/4}$$

We'll see this again when it comes to $e^+e^- \rightarrow Z^0$

NON-EXAMINABLE

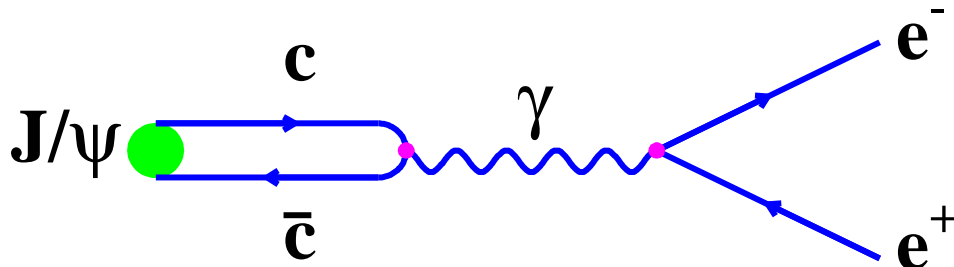
APPENDIX: $\Gamma_{J/\psi \rightarrow e^+e^-}$ Calculation of the partial width for $J/\psi \rightarrow e^+e^-$ 

Notation : J/ψ mass = m_ψ , Q_c is charge of charm quark, electron/positron energy $E_e = m_\psi/2$ (neglecting m_e)

$$\begin{aligned} \Gamma_{e^+e^-} &= \hbar T_{fi} \\ &= 2\pi |M|^2 \rho(E_e) \\ \text{neglecting } m_e \quad d\rho(E_e) &= \frac{E_e^2 d\Omega}{(2\pi)^3} \end{aligned}$$

Assume isotropic decay and integrate over solid angle:

$$\begin{aligned} \rho(E_e) &= \frac{4\pi E_e^2}{(2\pi)^3} \\ E_e = \frac{m_\psi}{2} \quad \Rightarrow \quad \rho(E_e) &= \frac{\pi m_\psi^2}{(2\pi)^3} \end{aligned}$$

Matrix element:

$$\begin{aligned} M &= \langle e^+ e^- | \frac{1}{q^2} | \bar{c} Q_c e c \rangle \\ M &= Q_c e^2 \frac{1}{q^2} \psi_{c\bar{c}}(0) \\ |M|^2 &= Q_c^2 (4\pi\alpha)^2 \frac{1}{q^4} |\psi_{c\bar{c}}(0)|^2 \end{aligned}$$

$$q = (E_\psi, \vec{0}) = (m_\psi, \vec{0})$$

$$|M|^2 = \frac{Q_c^2 (4\pi\alpha)^2}{m_\psi^4} |\psi_{c\bar{c}}(0)|^2$$

$$\begin{aligned} \Gamma_{e^+e^-} &= 2\pi \frac{Q_c^2 (4\pi\alpha)^2}{m_\psi^4} |\psi_{c\bar{c}}(0)|^2 \frac{\pi m_\psi^2}{(2\pi)^3} \\ &= 4\pi \frac{Q_c^2 \alpha^2}{m_\psi^2} |\psi_{c\bar{c}}(0)|^2 \end{aligned}$$

★ Need the wave-function of the $c\bar{c}$ system \Rightarrow probability that the $c\bar{c}$ are in the same place.

For arguments sake, take the wave-function of the J/ψ to correspond to that of ground state in the strong version of the Coulomb potential (*i.e.* Hydrogen atom):

$$\begin{aligned} \psi_{c\bar{c}}(r, \theta, \phi) &= \frac{1}{\sqrt{\pi}} \left(\frac{1}{a_0}\right)^{\frac{3}{2}} \exp\left(-\frac{r}{a_0}\right) \\ |\psi_{c\bar{c}}(r=0)|^2 &= \frac{1}{\pi} \left(\frac{1}{a_0}\right)^3 \\ \Gamma_{e^+e^-} &= 4 \frac{Q_c^2 \alpha^2}{a_0^3 m_\psi^2} \end{aligned}$$

Take $a_0 = 1.5 \text{ GeV}^{-1} = 0.3 \text{ fm}$ which is a reasonable value for actual potential.

$$\Gamma_{e^+e^-} = 4 \left(\frac{2}{3}\right)^2 \left(\frac{1}{137}\right)^2 \left(\frac{1}{1.5}\right)^3 \left(\frac{1}{3.1}\right)^2 \text{ GeV}$$

$$\Gamma_{e^+e^-} = 2.9 \times 10^{-6} \text{ GeV} = 2.9 \text{ keV}$$

$$\text{EXPERIMENTAL VALUE} = 5.1 \text{ keV}$$

It is somewhat fortuitous that we obtain roughly the correct answer. Many approximations, e.g. the wave-function will not correspond to that in a Coulomb potential,...

The calculation illustrates a number of points:

- ★ Decay rates are hard to calculate, we are no longer dealing with fundamental particles.
- ★ Need to know the wave-function of the decaying state.
- ★ Need to know the QCD potential

However calculations of ratios more reliable since they use same assumptions.

ANOTHER EXAMPLE:

The $\Upsilon(9460)$ is the $b\bar{b}$ state corresponding to the J/ψ .

$$\Gamma_{\Upsilon \rightarrow e^+e^-} = 4 \frac{Q_b^2 \alpha^2}{a_0^3 m_\Upsilon^2}$$

For a Coulomb potential

$$a_0 = \frac{3}{2m_q \alpha_s}$$

$$\frac{\Gamma_{J/\psi \rightarrow e^+e^-}}{\Gamma_{\Upsilon \rightarrow e^+e^-}} = \frac{Q_c^2 m_c^3 \alpha_s^3 (3.1) m_\Upsilon^2}{Q_b^2 m_b^3 \alpha_s^3 (9.5) m_\psi^2}$$

$$= 4 \frac{1.5^3}{4.75^3} \frac{0.3^3}{0.2^3} \frac{9.5^2}{3.1^2}$$

$$= 4.0$$

$$\text{EXPT. } \frac{\Gamma_{J/\psi \rightarrow e^+e^-}}{\Gamma_{\Upsilon \rightarrow e^+e^-}} = \frac{5.1}{1.25} = 4.1 \pm 0.2$$

NOTE the use of a running value of α_s

APPENDIX : Charmonium

NON-EXAMINABLE

Compare bound $c\bar{c}$ states (**CHARMONIUM**), with bound e^+e^- states **POSITRONIUM**

For Positronium use non-relativistic Schrödinger Equation with

$$V_{em} = -\frac{\alpha_{em}}{r}$$

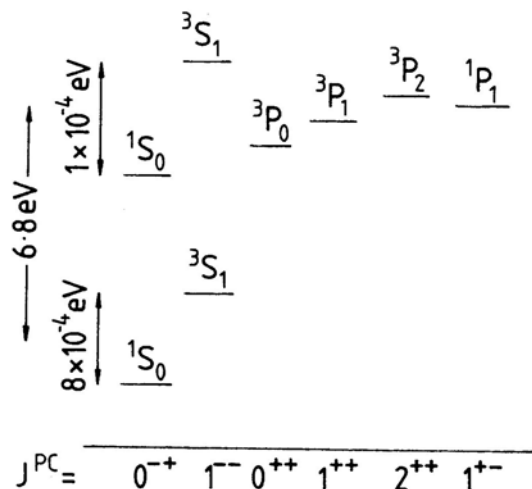

$$E_n = -\frac{\alpha_{em}^2 m_e}{4n^2}$$

Levels split by spin-spin and spin-orbit interactions \Rightarrow FINE STRUCTURE

$$\Delta E_n \sim \frac{\alpha_{em}^4 m_e}{n^3}$$

For lowest energy bound $c\bar{c}$ states can still use non-relativistic Schrödinger Equation

$$V_{QCD} = -\frac{4}{3} \frac{\alpha_S}{r} + kr$$

for QCD potential \Rightarrow solve numerically

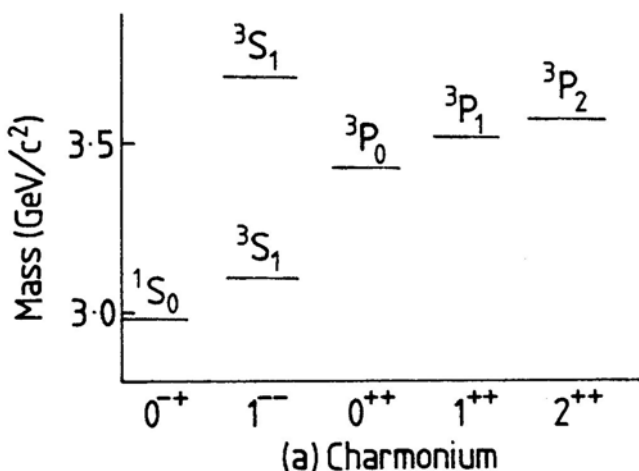

Relative magnitude of FINE STRUCTURE

$$\frac{\Delta E_n}{E_n} \sim \frac{\alpha^2}{n}$$

$\alpha_S \Rightarrow$ larger splitting.